

DNFT-LCC

P/N: 000360

SPECIFICATIONS

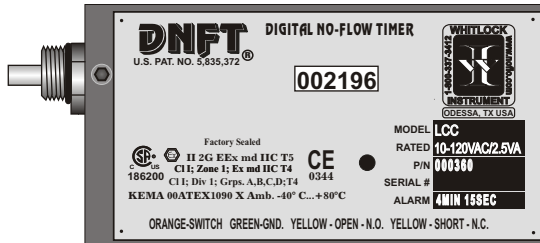

Material.....Stainless Steel, Aluminum
 Temperature Range..... -40°F to +185°F
 Switch Rating AC..... 10-120VAC/2.5 VA
 Switch Rating DC.....240VDC/2.5VA
 Epoxy Encapsulated.....UL LISTED EL-CAST VFR 641
 Power.....Field Replaceable Lithium Battery
 Alarm/Shutdown.....Factory Default for
 4 minute 15 Seconds alarm
 Battery.....P/N000505
 Divider Block Application.....Dropsa/Lincoln/
 SBCO/Lubriquip
 Warranty.....2.5 Years



LCC

- MONITORS MOVEMENT OF DIVIDER VALVE PISTON FOR DEPENDABLE "TIMED" SHUTDOWN PROTECTION
- OPEN and CLOSED LOOP OPERATION
- INSTALLS DIRECTLY TO DIVIDER VALVE
- NOT AFFECTED BY TEMPERATURE OR OIL VISCOSITY
- REQUIRES NO EXTERNAL POWER
- FIELD REPLACEABLE BATTERY
- LCD DISPLAYS:
TOTAL DIVIDER VALVE CYCLES
- AC OR DC OPERATION

RATINGS



 II 2G EEx md IIC T5
 CI I; Zone 1; Ex md IIC T4
 186200
 CI I; Div 1; Grps. A,B,C,D;T4
 CE
 0344
 KEMA 00ATEX1090 X Amb. -40° C...+80° C

DESCRIPTION

The DNFT-LCC is a totally enclosed electronic device, combining the latest technology in microprocessor and transistor components for detecting Slow-Flow and No-Flow of divider block lubrication systems. The DNFT incorporates an oscillating crystal to accurately monitor the cycle time of the lubrication system to enable precisely timed shutdown capability. The magnet assembly and control housing mount directly to the divider valve to become an integral part of the lubrication system. The DNFT-LCC operates on field replaceable lithium battery. If battery voltage drops below normal operating levels, the DNFT goes into alarm mode and the unit cannot be restarted. The LCC comes with a liquid crystal display. The liquid crystal display indicates each divider valve cycle and total divider valve cycle. The LCC is factory programmed for a 3 minute alarm time.

OPERATION

Lubricant flow through the divider valve assembly forces the pistons to cycle back and forth causing a lateral movement of a magnet linked to the piston. Movement is monitored by the microprocessor which resets the timer, shows visual indication of divider valve cycles on the liquid crystal display and allows the unit to continue operation. Each change on the LCD indicates one complete cycle of the lubrication system. The microprocessor must receive this cycle in a predetermined time or a shutdown will occur. The DNFT will automatically reset alarm circuit when normal operation of divider valve resumes.

Distributed by:

TROUBLESHOOTING DNFT-LCC

NOTICE: WHEN MORE THAN ONE DNFT IS INSTALLED ON THE COMPRESSOR OR ENGINE, EACH DNFT MUST BE WIRED TO A SEPARATE ALARM CIRCUIT ON THE CONTROL PANEL, ANNUNCIATOR OR PLC TO SIMPLIFY TROUBLESHOOTING THE LUBRICATION SYSTEM AND DNFT.

| PROBLEM | POSSIBLE CAUSE | SERVICE PROCEDURE AND / OR CORRECTION |
|--|---|---|
| 1. LCD Does Not Change, Control Panel Indicates Lube No-Flow (See also, 3. Erratic shutdown) | A. Improperly Adjusted | Loosen set screws, slide DNFT all the way onto hex of magnet housing and torque to 25 inch pounds max. (Do not over tighten) Cycle divider valve by pumping clean oil through system with lubrication system purge gun or running compressor. If necessary, adjust DNFT 1/16" back until LCD changes with each cycle of divider valve |
| | B. Spring or Magnet is Broken in Magnet Assembly | Loosen set screws, remove DNFT from magnet housing. Remove magnet assembly from divider valve. Remove magnet, spacer and spring. Check components for damage. Replace damaged spring or magnet and install on divider valve. If necessary, adjust DNFT, number change on LCD. Purge air from system with lubrication system purge gun. |
| | C. Bent Magnet Housing | Loosen set screws, remove DNFT from magnet housing. Check for damaged or bent magnet housing. Remove magnet assembly from divider valve. Replace magnet housing, magnet, spring and spacer. Re-install DNFT on magnet housing. If necessary, adjust DNFT, check for number change on LCD. Purge air from system with lubrication system purge gun. |
| 2. No Display on LCD | A. Low Battery voltage B. Defective LCD | Remove the battery from the DNFT per the attached instructions. Replace the battery if the voltage is below 2.5 volts using a factory recommended replacement battery. |
| 3. After installation of DNFT, Rupture Disc is Blown and Divider Valve is Locked up. | A. Wrong Magnet Housing Installed on Divider Valve (See magnet assy. Below) | Loosen set screws, remove DNFT from magnet housing. Check for correct magnet housing for divider valve manufacturer. Remove and replace with correct magnet housing. If necessary, adjust DNFT, check for number change on LCD. Purge air from system with lubrication system purge gun. |
| | B. Air or Debris in Divider Valve System. | Check system pressure to insure oil is flowing to divider valves. If necessary install pressure gauge to monitor operation of lubrication system. 1. <u>Loosen</u> outlet plugs in front of valve blocks. Fast purge the system with lubrication system purge gun until clean, clear, air free oil appears from plugs. 2. <u>Loosen</u> each piston enclosure plug individually to purge air from behind piston. Do not remove piston enclosure plugs. Tighten all divider valve plugs. Adjust DNFT. To insure proper operation of the divider block lubrication system, it is absolutely necessary that all tubing and components be filled with oil and free of air before start-up. |
| Electrical Testing of LCC | | 1. NORMALLY OPEN - Attach ohmmeter to orange wires. Yellow wires should be insulated from each other. Ohmmeter should read 10 ohms or less in alarm state 2. NORMALLY CLOSED - Attach ohmmeter to read red wires. Yellow wires should be shorted together. Ohmmeter should read infinity in alarm mode |
| C. Faulty Lube Pump | | Check system pressure to insure oil is flowing to divider valve. If necessary, install pressure gauge to monitor operation of lubrication system. Check gauge to insure pump will build sufficient pressure to inject oil into cylinder. You cannot check for oil flow into cylinder by removing tubing from check valve and pumping oil to atmosphere. Replace pump. |

TYPICAL DNFT INSTALLATION

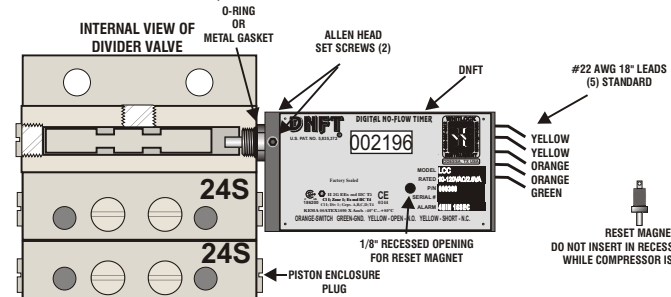

CAUTION: DISCONNECT ALL WIRING PRIOR TO WELDING ON COMPRESSOR OR SKID.

Magnet Assemblies and Applications

DNFT must be installed with correct magnet assembly for each divider valve manufacturer.

- SBCO & TRABON O-Ring Seal 7/16"-20 → Magnet Assy # 000004
- Trabon Metal Gasket Seal 1994 or Earlier 7/16"-20 → Magnet Assy # 000011
- Lincoln O-Ring Seal Extended Nose 7/16"-20 → Magnet Assy # 000012
- Dropsa No Gasket Raised Shoulder → Magnet Assy # 000013

DNFT-LCC INSTALLATION ON DROPSA/LINCOLN/SBCO/LUBRIQUIP DIVIDER BLOCKS.

- Loosen all Allen head set screws (A) on DNFT-LCC (B) and remove magnet housing (C). Do not remove magnet, spring, or spacer from magnet housing.
- Remove piston enclosure plug (D) from end of divider valve where DNFT-LCC will be installed. The DNFT-LCC does not have to be installed on the top divider valve. It may be installed on any convenient divider valve, top to bottom. (**Notice:** Do not install DNFT-LCC on Lincoln divider valves with cycle indicator pins or any Dropsa divider valve less than SMX 16.)
- Be sure O-ring or metal gasket (F) is in place on magnet housing (C). Screw magnet housing (C) into end of divider valve (E). Torque to 15 foot pounds max.
- Slide DNFT-LCC (B) all the way onto hex of magnet housing (C). Tighten set screws on hex of magnet housing. Torque 25 inch pounds max.
- The LCD (G) on the DNFT-LCC indicates total divider valve cycles and changes with each cycle. This enables operator to adjust the lubricator pump for correct cycle time and oil consumption recommended by compressor manufacturer. If the number on the LCD (G) does not change with compressor running or by manually pumping oil into divider valve, the DNFT-LCC must be adjusted.
- Before adjusting DNFT-LCC, divider valve must be cycling. This can be achieved with the compressor running or by manually pumping oil through the divider valve assembly with a hand priming pump.
- Adjustment is made by sliding the DNFT-LCC (B) all the way on the hex of the magnet housing (C). Tighten set screws on hex of the magnet housing to 25 inch pounds max. Check for LCD (G) change to confirm correct adjustment. If LCD (G) does not change with divider valve cycling, adjust the DNFT-LCC back in 1/16" increments. Correct adjustment of the DNFT-LCC is confirmed by number change on the LCD (G).
- All conduit and connections should be appropriate for area classification. **Notice:** Conduit and fittings must be supported to avoid bending magnet housing.
- After installing magnet assembly and pre-compressor start-up, it is absolutely necessary to purge all air from divider block lubrication system. This can easily be accomplished with a lubrication system purge gun.**
- DNFT-LCC must be installed with correct magnet assembly for each divider valve manufacturer.
 - Lincoln-7/16"-20 extended nose with O-ring
 - Trabon-1994 or earlier 7/16"-20 with metal crush gasket
 - Dropsa-1/4" BSP with special metal spacer
 - Trabon-1995 and later 7/16"-20 with O-ring

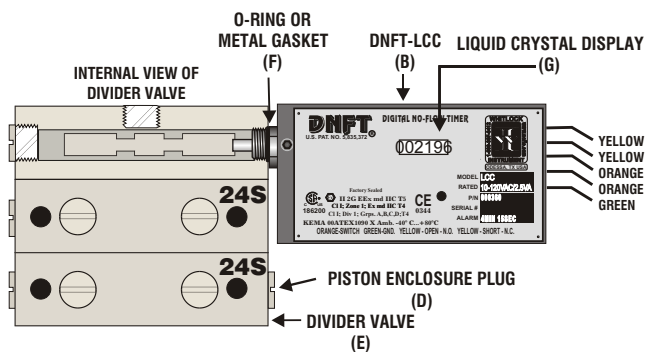

CAUTION: DISCONNECT ALL WIRING PRIOR TO WELDING ON COMPRESSOR OR SKID.

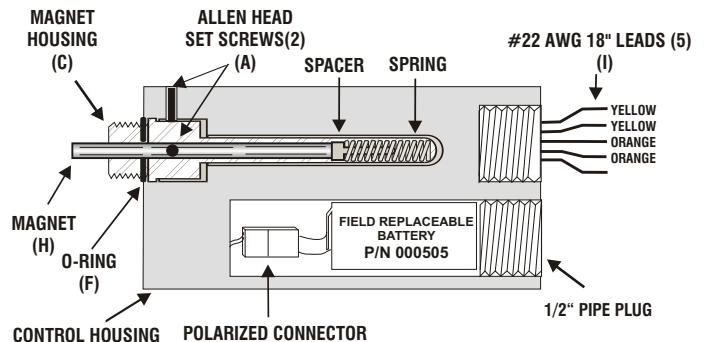

WIRING LEGEND

- YELLOW: WIRES SHORTED - NORMALLY CLOSED OPERATION
 - YELLOW: WIRES ISOLATED - NORMALLY OPEN OPERATION
 - ORANGE: SWITCH ORANGE: SWITCH
 - GREEN: CASE GROUND
- NOTICE: GROUND MUST BE CONNECTED. UNIT MUST BE SECURELY

DNFT-LCC 000360

OPEN LOOP MODE

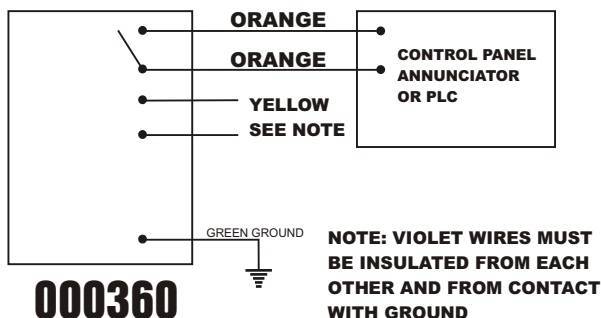

CLOSED LOOP MODE

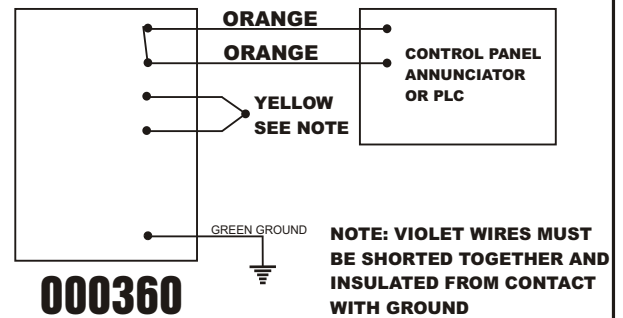

WIRING CONNECTIONS SHOWN FOR UNIT IN OPERATING MODE

DNFT BATTERY REPLACEMENT INSTRUCTIONS

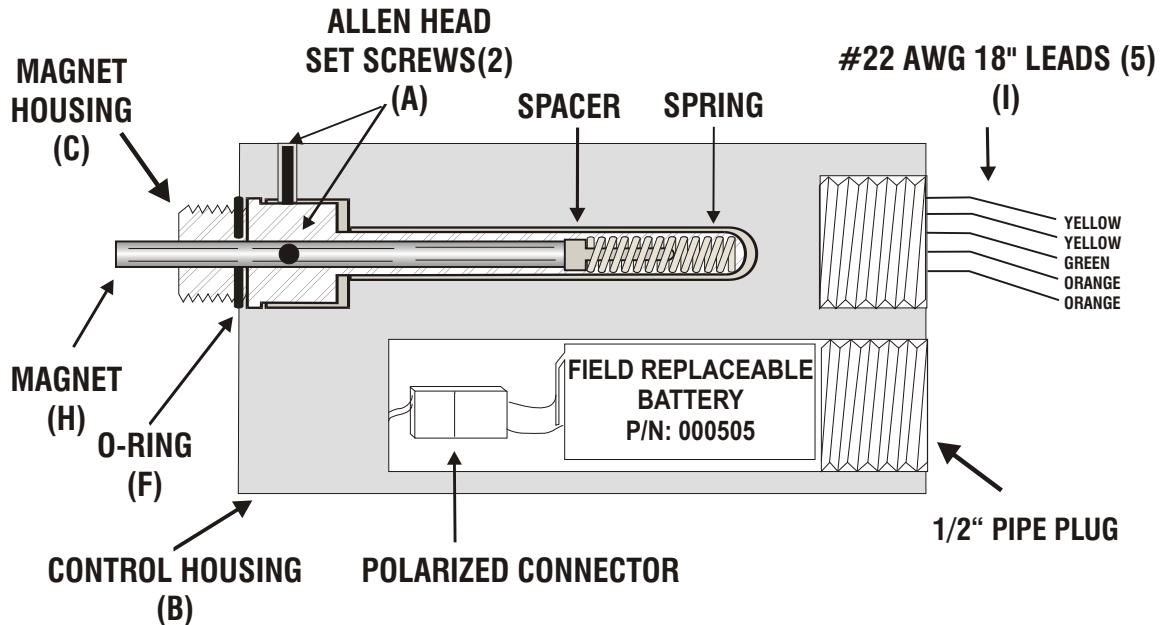

Directions for replacing the battery in the Digital No Flow Timer.

1. Shut down the engine or set the bypass timer.
2. Use a 3/8" ratchet to remove the 1/2" NPT Pipe plug.
3. Remove the battery from the DNFT and disconnect from the polarized connector.
4. Connect the new battery to the attached polarized plug.
5. Reinsert the battery and reinstall 1/2" NPT Pipe plug.
6. Verify the DNFT is working by pre-lubing the system and check for LCD number change.

ITEMS REQUIRED FOR REPLACING THE DNFT BATTERY:

- (1) P/N: 000505 BATTERY or RADIO SHACK P/N: 960-0418 (alternate replacement)
- (1) 3/8" RATCHET WRENCH (for removal of battery plug)

For any further information or questions, please contact:

WHITLOCK INSTRUMENTS
1300 N. Texas
Odessa, TX 79761
432.3373412 Fax 432.335.5926
1.800.337.3412 www.noflo.com