

DNFT-LED

P/N: 000506

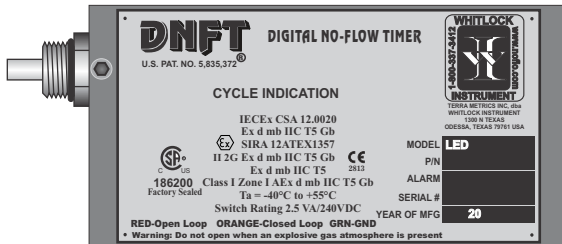



DNFT-LED

SPECIFICATIONS

Temperature Range.....	-40°C to +55°C
Switch Rating.....	2.5VA/240 VDC
PRX Rating.....	2.5VA/200 VDC MAX/0.5A
Epoxy Encapsulated.....	UL LISTED EL-CAST VFR 641
Alarm/Shutdown.....	Factory default for 2 minute alarm
Power.....	Field Replaceable - Lithium Battery 3.6 Volt, 1.5Ah, 75mA MAX Contentious Current
Battery.....	P/N 000505
Divider Block Application.....	Dropsa/Lincoln/SBCO/Lubriquip
Warranty.....	2.5 Years

RATINGS

 186200 Factory Sealed	IECEx CSA 12.0020  SIRA 12ATEX1357  II 2G Ex d mb IIC T5 Gb Ex d mb IIC T5 Class I Zone I AEx d mb IIC T5 Gb Ta = -40°C to +55°C Switch Rating 2.5 VA/240VDC PRX 2.5 VA/200VDC MAX/0.5mA
--	---

- MONITORS MOVEMENT OF DIVIDER VALVE PISTON FOR DEPENDABLE "TIMED" SHUTDOWN PROTECTION
- CLOSED LOOP OR OPEN LOOP OPERATION
- INSTALLS DIRECTLY TO DIVIDER VALVE
- NOT AFFECTED BY TEMPERATURE OR OIL VISCOSITY
- REQUIRES NO EXTERNAL POWER
- LED INDICATOR - CYCLE INDICATION
- DEDICATED SWITCH CLOSURE TO MONITOR EACH DIVIDER VALVE CYCLE (PS OPTION 000507 ONLY)
- FIELD REPLACEABLE BATTERY

DESCRIPTION

The DNFT-LED is a totally enclosed electronic device, combining the latest technology in microprocessor and transistor components for detecting Slow-Flow and No-Flow of divider block lubrication systems. The DNFT incorporates an oscillating crystal to accurately monitor the cycle time of the lubrication system to enable precision timed shutdown capability. The magnet assembly and control housing mount directly to the divider valve to become an integral part of the lubrication system. The DNFT operates on a field replaceable lithium battery. If battery voltage drops below normal operating levels the DNFT goes into alarm mode and the unit cannot be restarted. LED models utilize an LED to indicate each cycle of the divider valve. This enables the operator to easily set and monitor lubrication rates. The DNFT has been designed and rated for use in Class I Zone I environments, to be used outdoors in wet or dry locations, in altitudes under 2000 meters, with a Pollution Degree of 4.

OPERATION

Lubricant flow through the divider valve assembly forces the pistons to cycle back and forth causing a lateral movement of a magnet linked to the piston. Movement is monitored by the microprocessor which resets the timer, lights the LED, and allows the unit to continue operation, this indicates one complete cycle of the lubrication system. The microprocessor must receive this cycle in a predetermined time or a shutdown will occur. The DNFT will automatically reset alarm circuit when normal operation of divider valve resumes.

Distributed by:

P/N 000506 DNFT-LED DIGITAL NO-FLOW TIMER WITH DEDICATED PROXIMITY SWITCH. INSTALL ON DROPSA/LINCOLN/SBCO/LUBRIQUIP DIVIDER BLOCK. SWITCH RATING 2.5VA 240VDC

- Loosen all Allen head set screws (A) on DNFT (B) and remove magnet housing (C). Do not remove magnet, spring or spacer from magnet housing.
- Remove piston enclosure plug (D) from end of divider valve where DNFT will be installed. The DNFT does not have to be installed on the top divider valve. It may be installed on any convenient divider valve, top to bottom. (Notice: Do not install DNFT on Lincoln divider valves with cycle indicator pins or any Dropsa divider valve less than SMX 16.)
- Be sure O-ring (F) is in place on magnet housing (C). Screw magnet housing (C) into end of divider valve (E). Torque to 15 foot pounds max.
- Slide DNFT (B) all the way onto hex of magnet housing (C). Tighten set screws on hex of magnet housing. Torque 25 inch pounds max.
- The LED on the DNFT indicates each divider valve cycle. This enables operator to adjust the lubricator pump for correct cycle time and oil consumption recommended by compressor manufacturer. If LED does not blink with compressor running or by manually pumping oil into divider valve, the DNFT must be adjusted. Normal cycle indication is a bright strobe type blink.
- Before adjusting DNFT, divider valve must be cycling. This can be achieved with the compressor running or by manually pumping oil through the divider valve assembly with a hand priming pump.
- Adjustment is made by sliding the DNFT (B) all the way on the hex of the magnet housing (C). Tighten set screws on hex of the magnet housing to 25 inch pounds max. Check for LED blink to confirm correct adjustment. If LED does not blink with divider valve cycling, adjust the DNFT back in 1/16" increments. Correct adjustment of the DNFT is confirmed by blinking LED.
- All conduit and connections should be appropriate for area classification. Notice: Conduit and fittings must be supported to avoid bending magnet housing.
- After installing magnet assembly and pre-compressor start-up, it is absolutely necessary to purge all air from divider block lubrication system. This can easily be accomplished with a lubrication system purge gun.
- DNFT must be installed with correct magnet assembly for each divider valve manufacturer.
 - Lincoln-7/16"-20 extended nose with O-ring
 - SBCO & Trabon-1995 and up 7/16"-20 with O-ring
 - Dropsa

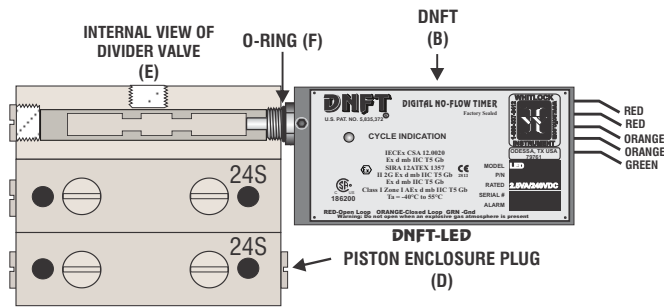

CAUTION: DISCONNECT ALL WIRING PRIOR TO WELDING ON COMPRESSOR OR SKID.

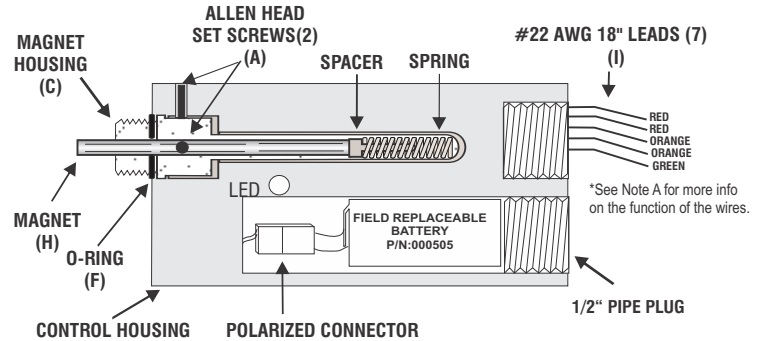

Notice: When installing more than one DNFT, each DNFT must be wired to a separate alarm circuit of the control panel, annunciator, or PLC to simplify troubleshooting the lubrication system and DNFT.

Note: The DNFT shall be installed in such a way that there is a low risk of mechanical danger.

Warning: DO NOT OPEN when an explosive gas atmosphere is present.

***NOTE A:**

Output Alarm Wires: The orange or red alarm wires are used to connect the DNFT to a PLC, annunciator, or other control monitoring device. The alarm wires will open or close, depending on which wires are used, to indicate a fault in the lubrication system.

Device Operation Wires: Orange Wires are used where a Normally Closed Circuit is required. Red Wires are used where a Normally Open Circuit is Required.

Green Ground Wire: The green ground wire is used to ground the DNFT from stray voltages or currents floating around the natural gas compressor package.

OPEN LOOP MODE

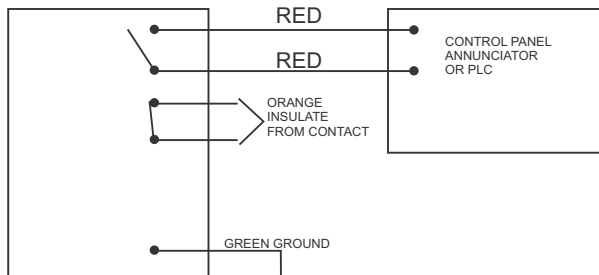

PN: 000506

NOTE: WIRING CONNECTION FOR UNIT IN OPERATION

CLOSED LOOP MODE

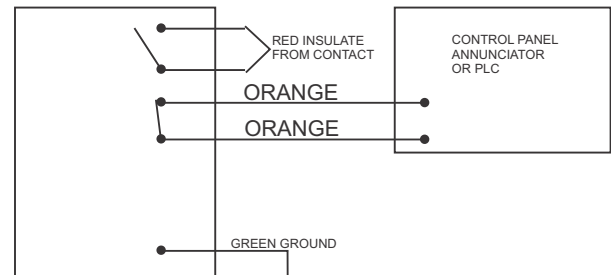

PN: 000506

NOTE: WIRING CONNECTION FOR UNIT IN OPERATION

TROUBLESHOOTING DNFT-LED

NOTICE: WHEN MORE THAN ONE DNFT IS INSTALLED ON THE COMPRESSOR OR ENGINE, EACH DNFT MUST BE WIRED TO A SEPARATE ALARM CIRCUIT ON THE CONTROL PANEL, ANNUNCIATOR OR PLC TO SIMPLIFY TROUBLESHOOTING THE LUBRICATION SYSTEM AND DNFT.

PROBLEM	POSSIBLE CAUSE	SERVICE PROCEDURE AND / OR CORRECTION
1. LED does Not Blink, Control Panel Indicates Lube No-Flow (See also, 3. Erratic shutdown)	A. Improperly Adjusted DNFT	Loosen set screws, slide DNFT all the way onto hex of magnet housing and torque to 25 inch pounds max. (Do not over tighten) Cycle divider valve by pumping clean oil through system with lubrication system purge gun or running compressor. If necessary, adjust DNFT 1/16" back until LED blinks with each cycle of divider valve.
	B. Spring or Magnet is Broken in Magnet Assembly	Loosen set screws, remove DNFT from magnet housing. Remove magnet assembly from divider valve. Remove magnet, spacer and spring. Check components for damage. Replace damaged spring and/or magnet and install on divider valve. If necessary, adjust DNFT, check for LED blink. Purge air from system with lubrication system purge gun.
	C. Low Battery voltage	Remove the battery from the DNFT per the attached instructions. Replace the battery if the voltage is below 2.5 volts using a factory recommended replacement battery.
	D. Bent Magnet Housing	Loosen set screws, remove DNFT from magnet housing. Check for damaged or bent magnet housing. Remove magnet assembly from divider valve. Replace magnet housing, magnet, spring and spacer. Re-install DNFT on magnet housing. If necessary, adjust DNFT, check for LED blink. Purge air from system with lubrication system purge gun.
2. After installation of DNFT, Rupture Disc is Blown and Divider Valve is Locked up.	A. Wrong Magnet Housing. Installed on Divider Valve (See magnet assy. Below)	Loosen set screws and remove DNFT from magnet housing. Check for correct magnet housing for divider valve manufacturer. Remove and replace with correct magnet housing. Replace DNFT on magnet housing. If necessary adjust DNFT, check for LED blink. Purge air from system with lubrication system purge gun.
	B. Air or Debris in Divider Valve System.	Check system pressure insure oil is flowing to divider valves. If necessary install pressure gauge to monitor operation of lubrication system. 1. <u>Loosen</u> outlet plugs in front of valve blocks. Fast purge the system with lubrication system purge gun until clean, clear, air free oil appears from plugs. 2. <u>Loosen</u> each piston enclosure plug individually to purge air from behind piston. <u>Do not</u> remove piston enclosure plugs. Tighten all divider valve plugs. Adjust DNFT. <u>To insure proper operation of the divider block lubrication system, it is absolutely necessary that all tubing and components be filled with oil and free of air before start-up.</u>
ELECTRICAL TESTING OF DNFT ALARM CIRCUIT		1. NORMALLY OPEN - Attach ohmmeter to red wires. Meter should read 10 megaohms in operation and less than 10 ohms in alarm state. 2. NORMALLY CLOSED - Attach ohmmeter to orange wires. Meter should read less than 10 ohms in operation and infinity in alarm state.
Faulty Lube Pump		Check system pressure to insure oil is flowing to divider valves. If necessary, install pressure gauge to monitor operation of lubrication system. Check gauge to insure pump will build sufficient pressure to inject oil into cylinder. You cannot check for oil flow into cylinder by removing tubing from check valve and pumping oil to atmosphere. Replace pump.

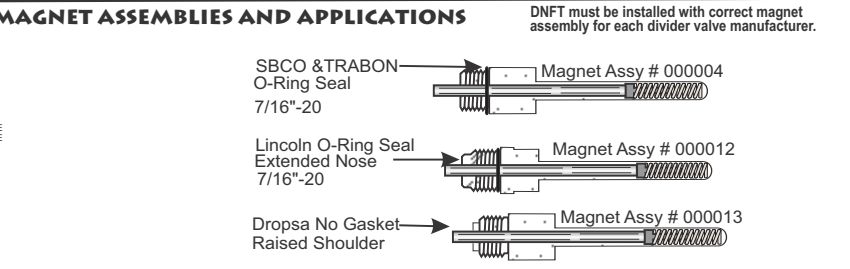
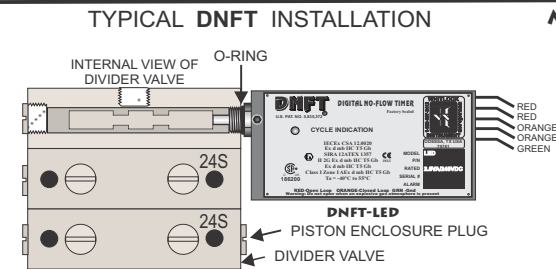
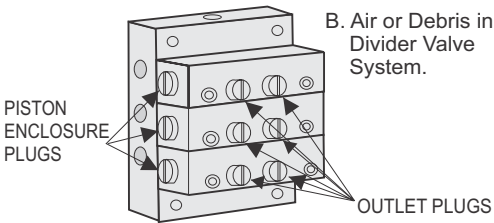
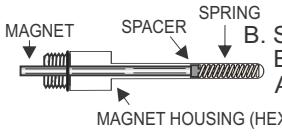

CAUTION: DISCONNECT ALL WIRING PRIOR TO WELDING ON COMPRESSOR OR SKID.

DNFT BATTERY REPLACEMENT INSTRUCTIONS

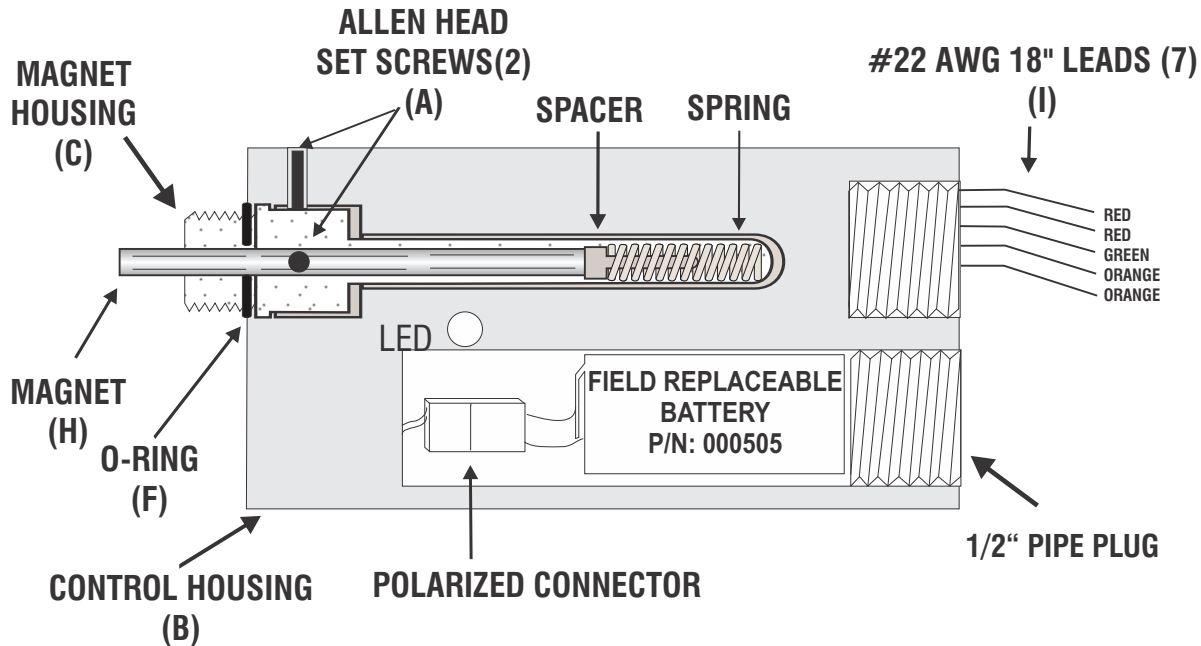

Directions for replacing the battery in the Digital No Flow Timer.

1. Shut down the engine or set the bypass timer.
2. Use a 3/8" ratchet to remove the 1/2" NPT Pipe plug.
3. Remove the battery from the DNFT and disconnect from the polarized connector.
4. Connect the new battery to the attached polarized plug.
5. Reinsert the battery and reinstall 1/2" NPT Pipe plug.
6. Verify the DNFT is working by pre-lubing the system and check for LED blink.

ITEMS REQUIRED FOR REPLACING THE DNFT BATTERY:

- (1) P/N: 000505 BATTERY
- (1) 3/8" RATCHET WRENCH (for removal of battery plug)

For any further information or questions, please contact:

**Terra Metrics Inc, dba
WHITLOCK INSTRUMENT**
1300 N. Texas
Odessa, TX 79761 USA
432.337.3412 Fax 432.335.5926
1.800.337.3412
www.noflo.com